

# SELF-RECONFIGURABLE ROBOTS FOR ADAPTIVE AND MULTIFUNCTIONAL TASKS

Wei-Min Shen

USC/ISI Polymorphic Robotics Laboratory  
4676 Admiralty Way, Marina del Rey, CA 90292

## ABSTRACT

Self-reconfigurable modular robots are metamorphic systems that can autonomously change their logical or physical configurations (such as shapes, sizes, or formations), as well as their locomotion and manipulation, based on the mission and the environment in hand. Because of their modularity, versatility, self-healing ability and low cost reproducibility, such robots provide a flexible approach for achieving complex tasks in unstructured and dynamic environments. This paper gives an overview of an existing self-reconfigurable robot called SuperBot, and describes its control method for diverse behaviors, its self-reconfigurable connectors, and some experimental results for adaptive and multifunctional tasks for Army applications.

## 1. INTRODUCTION

Research in self-reconfigurable robots have been active in academic for many years, but it is only recently that the results of these research are beginning to be used and applied to serious real-world applications such as sustainable space exploration, military, homeland security, and others. It is the right time for Army applications because many researchers are seeing the values of the field, and many companies are beginning to investigate their resources, and because it has become ever convincing that modularity and reconfiguration are the keys to construct large systems reliably and economically.

The construction and control of these robots, however, are very challenging due to the dynamic topology of the module network, the limited resource of individual modules, the difficulties in global synchronization, the preclusion of centralized decision makers, and the unreliability of communication among modules.

The current research in this field has made excellent progress in low-level module construction, locomotion, reconfiguration, or resilience to body damage. For example, SuperBot is one of the leading systems in the field built by our Polymorphic Robotic Lab. SuperBot (Shen, et. al., 2006, Salemi, et. al., 2006) is made of many autonomous, intelligent, and self-reconfigurable (software or hardware) modules, and provide multifunction, adaptation, resilience, and reuse. The modules can change configurations to enable different modes of locomotion, such as slither, crawl, walk,

run, roll, climb, dig, bury, swim, fly, hover, and different tasks, such as delivering payloads, gathering data, and so on. This modular architecture can also be applied to other military applications to enable self-assembly, self-reconfiguration, and self-repairing of sensors, devices, vehicles, robots, and other autonomous systems. The modules can be mass-produced to reduce cost and become exchangeable and disposable in applications.

Many effective controls of self-reconfigurable robots are inspired by existing models found in biology, including tissue-regeneration, epimorphosis, morphallaxis, diffusion-reaction, potential fields, cellular automata, and others. Most of them model how metamorphosis takes place at the cellular level once the process is triggered. For example, this paper uses a US patented *hormone-inspired model* (Shen, et. al., 2002, 2004) that can mimic how cells can self-organize and self-heal even after severe disturbance or damage to their initial configuration. The same model can also control distributed and reliable self-reconfiguration, locomotion, manipulation, topology discovery, role negotiation, synchronization, role-based behavior, and detecting and repairing damage. A related model is developed for *scalable self-healing* (Rubenstein and Shen 2008), a process that can start from any subset and rebuild a new whole with the original spatial, visual, and temporal patterns in a scale proportional to the number of elements available. Nevertheless, no existing biological or mathematical model in the field can yet enable an intelligent organism or an autonomous system to deliberately and purposefully control metamorphosis as a means of active adaptation.

The concept of “adaptation” is a main concern for both Artificial Intelligence and Cognitive Science, with a close relationship with robotic research. It is about the change of behaviors or learning new knowledge in problem solving. The adaptive methods include reinforcement learning, learning finite state machines, hidden Markov models, partially observable Markov decision processes, support vector machines, predictive state representations, and temporal difference algorithms. SuperBot uses a new learning method called Surprise-Based Learning (SBL). The powerful and intuitive idea of SBL is that every surprise contains critical new information for the learner to create or improve its knowledge. This adaptive method has been demonstrated in many domains (Shen 1994) and recently implemented and tested on SuperBot (Ranasinghe and Shen, 2008) to show that it can recover from physical sensor/action failures. New research is planned to extend this adaptive

algorithm to learn new body configurations and determine the relationships between functions and shapes from the environment. Our ultimate goal is to enable the robot to autonomously learn from surprises and mistakes and determine its optimal shape, size, and configuration for a given task and situation.

## 2. OVERVIEW OF SUPERBOT

SuperBot is a self-reconfigurable robot built at USC/ISI Polymorphic Robotic Laboratory that can adapt its shape, size, and configuration to unexpected situations and tasks. Figure 1 shows some of the best examples of its different configurations for rolling, climbing ropes, crawling on beach, standing, slithering, wiggling, climbing a river bank, going through pipes, digging, stroking, tele-operating, and carrying payloads. Movies of these diverse behaviors are available at <http://www.isi.edu/robots/>.

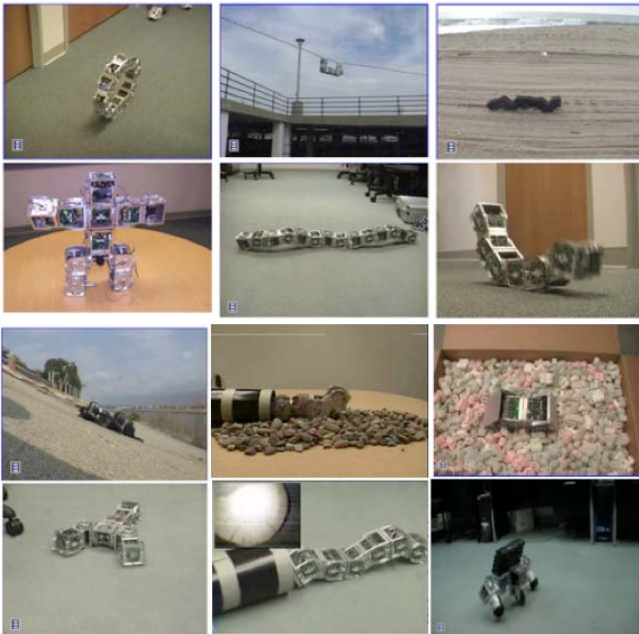

Figure 1: SuperBot configurations and behaviors.

SuperBot uses a hormone-inspired distributed control (Shen et. al., 2004) for its diverse behaviors in locomotion, manipulation, self-reconfiguration and self-healing. The approach is inspired by the biological concept of hormones (thus the name digital hormones) and it provides a unified solution for metamorphic systems self-reconfiguration, self-assembly, locomotion, and manipulation. Modules are modeled as autonomous agents free from globally unique identifiers and they can physically connect and disconnect with each other and can communicate via content-based messages. In particular, the totally distributed method can support a general representation for self-reconfigurable systems, and provide distributed solutions for task negotiation, topology-dependent behavior selection and synchronization, detection and reaction for topology changes and message loss, endure configuration damage such as

bifurcation, unification, loss of modules, and other shape-alternations. The modules in the robot will autonomously change their behavior based on their locations in the current function. We refer this type of behaviors as topology-triggered behaviors and they are critical for adaptation and self-healing.

## 3. SELF-RECONFIGURABLE CONNECTORS

To realize the full potential of self-reconfigurable robots, a flexible and reliable connection mechanism is an essential. Such a mechanism will enable the elements in a system to physically connect and reconnect to form different configurations, shapes, and assemblies. Applications would include, among others, self-assembly in space or underwater, self-reconfigurable robotic systems for multifunctional applications, reconfigurable, and flexible manufacturing, reconfigurable tools/devices for dynamic situations.

One critical requirement of such connection mechanisms is that they must be single-end-operative, that is, able to establish or disengage a connection even if one end of the connection is not operational. This is necessary because components in a system may be unexpectedly damaged or deliberately taken out of service, yet the process of self-organization must go on. In other words, no connections should be seized permanently or disconnect unintentionally.

Another important consideration is the flexibility of the connection mechanism and whether it will allow any two components to connect. In any self-reconfigurable system, there is a delicate balance between having homogeneous components (for lower cost) and heterogeneous functions (for more applications). At one extreme, all components may have homogeneous structures and functions but the system is over-redundant and inefficient. At the other extreme, all components may be unique and special but such a system is subject to single point failures. Our design is to balance between the two extremes by having homogeneous robotic skeleton “bone” modules to connect heterogeneous devices, such as special sensors, actuators, power suppliers, tools, and protective shields. A genderless connector will greatly facilitate this vision because it allows any two components to connect without gender restrictions imposed by their connectors.

There are many existing connection mechanisms in the literature (Sproewitz, et. al., 2008). However, most do not yet support single-end-operations. For example, connections using permanent magnets (e.g., (Suh, et. al., 2002; Murata, et. al., 2002), electromagnetic force (e.g., (Goldstein, et. al., 2005; Zykov, et. al., 2005), or electrostatic force (e.g., (Karagozler, et. al., 2007) may lose a connection unintentionally if one end is out of service. Connections using physical latches and pins (e.g., (Shen and Will, 2001; Castano, et. al., 2002; Yim, et. al., 2003; Murata, et. al., 2001; Jorgensen, et. al., 2004; Unsal, et. al., 2001; Nilsson 2002; Mondada, et. al., 2004; Murata, et. al., 2007; Zykov and Lipson 2006) are mostly gendered and may be stuck permanently if one side is to malfunction.

To provide single-end-operation, we have designed a new connection mechanism called SINGO that is genderless and can change the state of a connection from either end. Theoretical analysis and prototype experiments have shown that this new connector can indeed offer the desired properties for flexibility, endurance, strength, and efficiency.

#### 4. THE DESIGN OF SINGO CONNECTOR

Figure 2 shows the design of the SINGO connector. The connector has a base on which four movable connector jaws are formed on one side to provide the single-end operative connection operation.

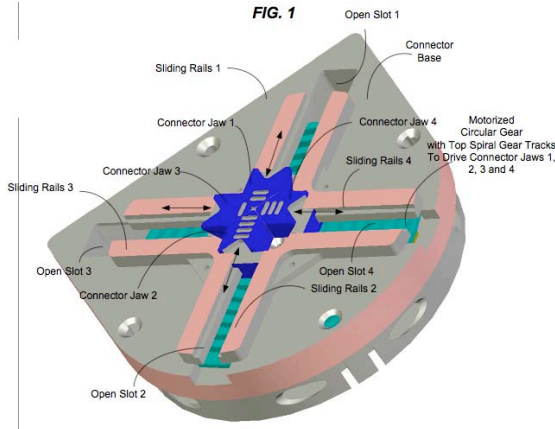

Figure 2: The SINGO connection mechanism.

Four linear sliding rails are formed in a symmetric cross configuration and meet at a center location (similar to a chuck). The connector jaws are movably engaged in the sliding rails respectively so that each connector jaw can move along its respective sliding rail. In operation, the connector jaws can move towards the center to engage to another connector and away from the center to disengage or vice versa depending on how two connectors are engaged to each other. The connector jaws are shaped to engage to the corresponding connector jaws of another such connector. The engagement happens either within the corresponding jaws of another connector or outside the corresponding jaws of another connector. To connect two such connectors, the four jaws on one connector are engaged to the four jaws of another connector to form a solid connection. To release, the four jaws on one connector are driven to be closed or opened to disengage with the other connector. The special shape of the jaw offers compliance during connector engaging and disengaging. The connector base is structured to have four open slots that are under the sliding rails, respectively, to expose a motorized circular gear mounted on the other side of the connector base that is engaged to the connector jaws and drives the connector jaws along their sliding rails, respectively. The motorized circular gear has top spiral or concentric gear tracks that are engaged to the bottoms of the connector jaws. As the motorized circular gear rotates, the connector jaws move along the radial direction of the motorized circular gear, along their respective sliding rails. Depending on the direction of the rotation of the motorized circular gear, the connector jaws

can move either towards the center to be close to one another or away from the center to be apart from one another. Because the connector jaws are driven by the common motorized circular gear, the connector jaws move in synchronization with one another. The entire mechanism is drivable by a single micro motor and is energy efficient.

When two connectors are connected, it is preferred that the jaws on both sides meet at the halfway of the rail to establish the connection. This state will ensure that any one side of this connection could release itself even if the other partner is inactive. To release from such an established connection, the active side will close its jaws all the way to the center if they are inside the jaws of the partner, or open its jaws all the way to the edge if they are outside the jaws of the partner. These movements will allow the active side disengages its jaws from the partner and release itself from the connection. To enter this desired state, the connectors will communicate during the docking process and decide which side is moving inwards and which side outwards.

The SINGO connector is genderless (homogeneous) and can be configured to realize desirable features such as strong and accurate mechanical linkage, long endurance, thin profile, compliant for misalignment, power efficiency, communication, docking guidance, and potentially offers power sharing and reliability in rough environments. For recoverability, a SINGO connector can disconnect even if the other side is damaged. One notable feature of the present design is the ability to reconfigure the connections between components and to autonomously join and disjoin components at will.

The present design can be used to provide various beneficial features, including: (1) homogeneous or genderless structure so that any connector can join with any other connector, (2) single side operation so that one connector can connect or release itself even if the other party is not operational due to damage or malfunction, (3) thin and efficient profile so that it is mechanically strong and consumes zero energy when connected or disconnected, (4) multi-orientation mode so that a connection can be made for every 90 degree, (5) self-alignment in both orientation and displacement during the connecting or engaging process, and (6) integration with sensors and controllers for autonomous operation and communication.

To provide the guidance for docking alignment, the connector can use either Infrared LEDs or laser signals for both docking guidance and communication between neighboring modules. The communication devices will be arranged in such a way that when two connectors are aligned they will have the maximal signal reception. The control algorithms for such guided docking process, including both alignment and the control of relative motions between the two docking connectors have been developed in the past [7, 17] and can be readily used for this new connector.

#### 5. PROTOTYPES FOR SELF-RECONFIGURABLE SUPERBOT

An immediate application of this new connector is for

modular self-reconfigurable robots. For this purpose, four prototype connectors have been constructed and integrated with the self-reconfigurable SuperBot. Figure 3 shows the dimension of the connector.

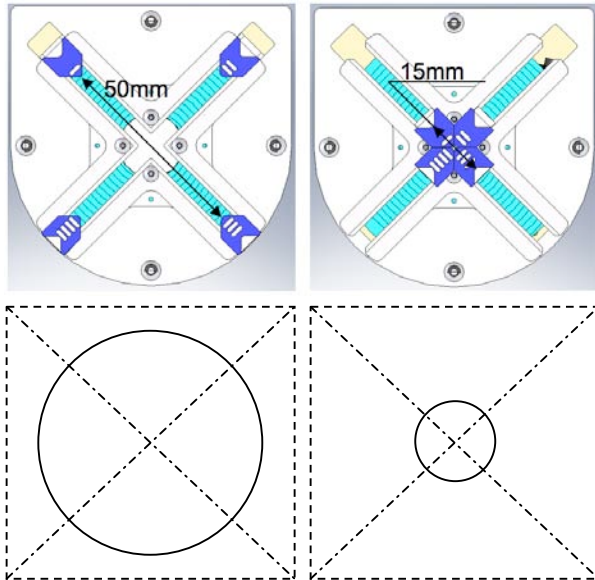
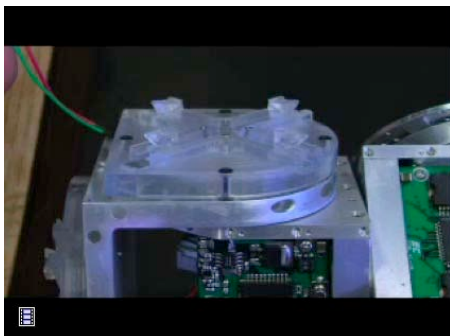
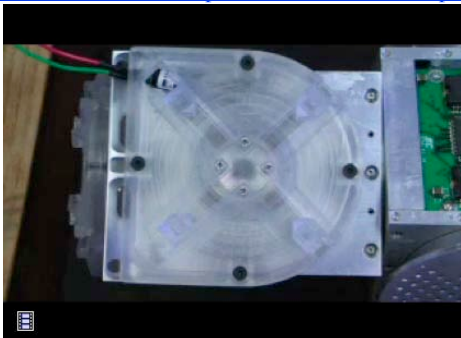

Figure 3: The prototyped dimension of the SINGO connector and the abstract diagrams representing the open and closed state of the connector.

The outline of the connector is 64mm in diameter and 14mm thick. When the four jaws are completely open, the max distance between jaws is 50mm. When they are closed at the center, the minimal distance across the jaws is 15mm. For the analysis in this paper, Figure 3 also shows two abstract figures to represent the open and closed states of the connector, respectively.



[http://www.isi.edu/robots/superbot/movies/side\\_4speed.swf](http://www.isi.edu/robots/superbot/movies/side_4speed.swf)



[http://www.isi.edu/robots/superbot/movies/front\\_4speed.swf](http://www.isi.edu/robots/superbot/movies/front_4speed.swf)



<http://www.isi.edu/robots/superbot/movies/closeupdock.swf>

Figure 4: The installed prototype connectors on the top, side, and front/back of the SuperBot modules.

The prototype connectors are designed so that they can be seamlessly integrated with the existing SuperBot modules. Figure 4 shows the installation of the connectors on the SuperBot module. The connector can be securely mounted on six different side of a SuperBot module (i.e., front, back, left, right, top, and bottom) for 3D reconfigurations. The three figures here show the mounting on the top, left, and front/back of a SuperBot module, respectively. The parts of the prototypes are constructed by a high-precision fast prototyping SLA machine with a durable plastic-like material. The total weight of a complete connector is about 50g.

Each prototype connector is driven by a micro-motor and it is powered and controlled by the internal battery and microprocessor in the SuperBot module. Each connector consumes about 40mA when opening or closing the jaws by itself and 65mA during engagement with another connector. The average speed of the moving jaws is about 1.0mm/second. The average time to establish a connection is about 25 second because the jaws need to travel at most 25mm, a half of the rail length, in order to bite each other in place. Movies of these operations are available at the links provided in Figure 4.

With the new connectors, SuperBot can demonstrate the desired capabilities for self-reconfiguration and self-healing. In the rest of the paper, we will analyze and demonstrate the various aspects of the new connectors, such as compliance, strength, single-end-operations, and self-reconfiguration.

## 6. COMPLIANCE FOR AUTONOMOUS DOCKING

Compliance for autonomous docking is one of the main requirements for any connection mechanism for self-reconfiguration, self-healing and self-assembly. During reconfiguration, connectors approach to and align with each other before establishing the connection. However, due to the uncertainties in sensing and control and the disturbance from the environment, no alignment can always be perfect. Thus, a connector should be able to tolerate these uncertainties when establishing the connection. The more a connector is tolerant to this, the better it is for autonomous docking.

The SINGO connector is designed to have sufficient compliance in the six dimension of the alignment, including longitude ( $x$ ), latitude ( $y$ ), separation ( $z$ ), pitch, yaw, and roll. These situations are illustrated in the pictures in Figure 5(a) through 5(d).



5(a): The compliance in  $x$  or  $y$  dimension



5(b): The compliance in  $z$  dimension (separation)



5(c): The compliance in **pitch** or **yaw** dimension

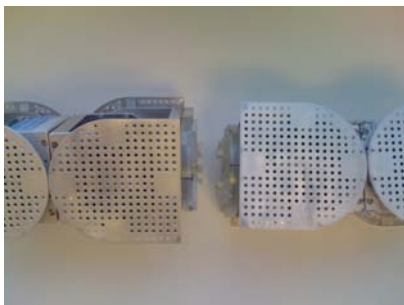

5(d): The compliance in **roll** dimension.

Figure 4: The six compliance dimensions during autonomous docking.

The compliance of the SINGO connector mainly comes from two factors of the design, the shape of the jaws, and the arrangement of the jaws. To illustrate how the shape of jaws

contributes to the compliance, Figure 6 shows the cross-sectional view and side view of the jaws during engagement. The matched slopes of the shape will guide and force the two engaging jaws to bite each other and automatically align with each other.

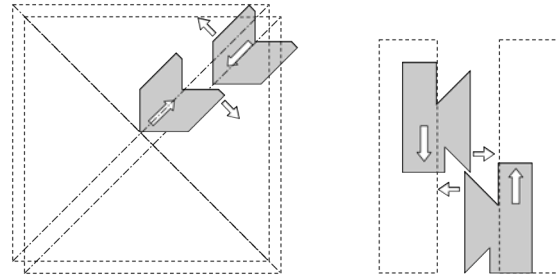

Figure 6: The shape of jaw contributes to automatic alignment in  $x$ - $y$ , and  $z$  dimension during the engagement process.

To see how the arrangement of the jaws contributes to the compliance, Figure 7 illustrates the possible misalignment of the two connectors in the  $x$  and  $y$  dimensions. The bigger circle represents the connector with the four jaws open, and the small circle the connector with the four jaws closed.

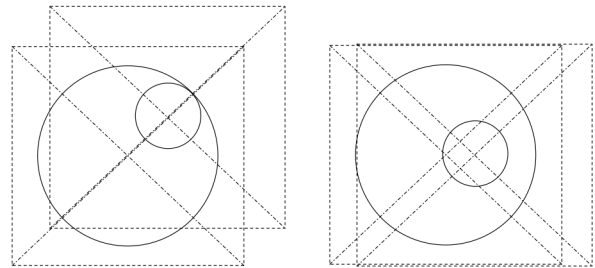

Figure 7: The arrangement and movement of the jaws along the sliding rails contribute to the max and min compliance in  $x$ - $y$  dimensions.

The left figure in Figure 6 shows the compliance,  $(50-15)=35\text{mm}$ , when the rails of two engaging connectors are aligned but the jaws are not. In this case, the closing of the outer jaws (the bigger circle) will force the inner jaws (the small circle) to the center.

The right figure in Figure 6 shows the compliance when the rails and jaws are both misaligned. In this case, the outer jaws will rely on their shape to force alignment of the inner jaws. The max allowed misalignment is equal to the half width of the jaws. In this prototype, the half width of a jaw is 5.0mm.

In the  $z$  dimension, a misalignment means that the two connectors starting the engagement when they are not yet touching each other and there is still a gap space between them (see the right figure in Figure 5). In this case, they must rely on the shape of the jaws to bring them closer. Clearly, the maximal compliance in this case is equal to the height of the jaw, which is 6.0mm in this prototype.

The compliance in the roll dimension is illustrated in the Figure 8, where we assume that the two connectors are aligned along the centerline, but with an error in the roll.

Thus, the maximal compliance in angle occurs when the inner jaws are closed at the center.

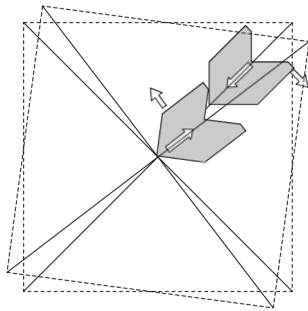
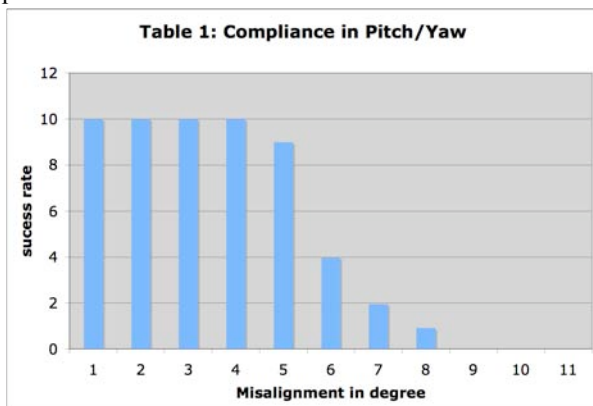

Figure 8: Compliance analysis in the roll dimension.

In this case, the angle is equal to  $\tan^{-1}(5\text{mm}/12\text{mm})=22^\circ$ , where 5 mm is the half width of the jaws, and the 12mm is the length of a jaw. The minimal compliance of roll occurs when the outer jaws are completely open. In that case, the allowed angle in the roll misalignment is  $\tan^{-1}(5\text{mm}/50\text{mm})=5.7^\circ$ . The compliance in the pitch and yaw dimension is more complex to analyze in abstract. So we use experiments to determine the values.



We manually place two connectors together with a measured error in the angle alignment while allow them to touch each other. We then turn on the connectors to let the jaws starting movement along the rails until they are successfully docked or fail to make an engagement. The introduced error in angle alignment is ranging from 0 degree to 10 degree. Ten experiments are performed for each introduced error and results are shown in Table I. We thus conclude that the compliance in the pitch or yaw dimension is about 5 degrees.

## 7. STRENGTH ANALYSIS AND EXPERIMENTS

The SINGO connector has the advantage of being strong once a connection is established. Since the jaws are driven by a motorized circular gear along their respective sliding rails, there is no backlash in their movement and position. This contributes greatly to the strength of the connector. The main deciding factor is the material of the jaws. As long as the jaws are not broken or chipped, the connection will endure its load. With the current plastic-like material we use

for the prototype, the connector can lift at least two other SuperBot modules (about 2.5kg) without any sign of breaking. Due the cost consideration, we did not perform any experiment to see how much weight or torque will break the jaws. However, we are confident that the strength of the connector is more than sufficient for the self-reconfiguration of the current SuperBot system. For the final production, the jaws will be made of metals and we expect the strength of the connector will increase considerably.

## 8. SINGLE-END-OPERATIONS

To demonstrate the ability for single-end-operation, we experimented with two Superbot modules using the SINGO connectors. The experiment is shown in Figure 9, where one module is powered while the other is not. We show that the powered module can first dock with, and then de-dock from the un-powered module. We then switch the power from one module to the other, and repeat the dock and de-dock process. In these and experiments below, the jaws of the connectors are engaged at the halfway of the rails to establish a connection, as we discussed before. The operations are successful and Table II illustrates the results of four possible combinations of the single-end-operation. A movie of this experiment is available at <http://www.isi.edu/robots/superbot/movies/autodock2.swf>.



Figure 9: An experiment for single-end-operation or self-healing.

Side A	Side B	Result
Engaging	Dead	Success
Disengaging	Dead	Success
Dead	Engaging	Success
Dead	Disengaging	Success

## 9. SELF-RECONFIGURATION EXPERIMENTS

To demonstrate the self-reconfigurability, we constructed a chain configuration of two SuperBot modules with the new connectors and programmed the chain to change its configurations autonomously. Figure 10 shows the sequence of such self-reconfiguration. The initial configuration (10a) is a chain of two modules connected by the connectors in the middle. Note that this configuration has two additional connectors at both ends. To make the configuration visually distinguishable, one end of the chain is marked with a yellow sign. The chain first bends the two ends together and

docks them forming a closed loop (10b). It then disconnects the initial (middle) connection and by doing so it forms a new chain configuration with the yellow sign in the middle (10c). It then bends and docks the two ends of the chain to form a new loop (10d and 10e), and then disconnects the middle connection and morphs back to the initial chain configuration (10f). This sequence shows that the SINGO connectors can be completely integrated with the SuperBot and can align, establish, and disengage connections in a self-reconfigurable robotic system. A movie of this experiment is at [http://www.isi.edu/robots/superbot/movies/auto\\_dock.swf](http://www.isi.edu/robots/superbot/movies/auto_dock.swf).



Figure 10: Self-reconfiguration (9a-9f) with SuperBot modules.

## 10. CONCLUSION

This paper gives an overview of self-reconfigurable modular robots that can autonomously change their logical or physical configurations (such as shapes, sizes, or formations), as well as their locomotion and manipulation, based on the mission and the environment in hand. Because of their modularity, versatility, self-healing ability and low cost reproducibility, such robots provide a flexible approach for achieving complex tasks in unstructured and dynamic environments. An existing self-reconfigurable robot called SuperBot is described as an example.

In addition, a new SINGO connector for self-reconfigurable and self-healing systems is described in detail. The unique features of this connector include the genderless (homogeneous) structure, strong and accurate mechanical linkage, long endurance, thin profile, compliant for misalignment, power efficient, supporting communication, docking guidance, and offers the possibility for sharing power. Theoretical analysis and experimental results have shown that this new connector can be seamlessly integrated with an existing self-reconfigurable robot, and can perform the desired compliance, speed, accuracy, flexibility, efficiency, and endurance. These features provide strong evidence for this new connection mechanism to be useful in many real-world applications.

## ACKNOWLEDGMENT

This work is in part supported by the SuperBot project sponsored by NASA Cooperative Agreement NNA05CS38A. The fast-prototyping SLA machine is

provided with support from Army DURIP Grant W911NF-05-1-0134. The theory for scalable self-healing is partly supported by Army research grant W911NF-04-1-0137. However, the views and opinions in this paper are solely of the authors. We would like to thank the members of the Polymorphic Robotics Laboratory at the University of Southern California, Information Sciences Institute, who provided their intellectual and system support during the course of this work.

## REFERENCES

- Shen, W.-M., M. Krivokon, H. Chiu, J. Everist, M. Rubenstein, and J. Venkatesh, 2006: Multimode locomotion for reconfigurable robots, *Autonomous Robots*, 20(2):165-177.
- Salemi, B., M. Moll and W.-M. Shen, 2006: SuperBot: A Deployable, Multi-Functional, and Modular Self-Reconfigurable Robotic System. *IEEE/RSJ Intl. Conf. on Intelligent Robots and Systems*.
- Shen, W.-M., B. Salemi, and P. Will, 2002: Hormone-Inspired Adaptive Communication and Distributed Control for CONRO Self-Reconfigurable Robots, *IEEE Transactions on Robotics and Automation*, 18(5).
- Shen, W.-M, P. Will, A. Galstyan, C.-M. Chuong, 2004: Hormone-inspired self-organization and distributed control of robotic swarms, *Autonomous Robots*, 17:93-105.
- Rubenstein and Shen 2008: A Scalable And Distributed Model for Self-organization and Self-healing. In *Proc. Intl. Conf. on Autonomous Agents and Multiagent Systems and IEEE/RSJ Intl. Conf. on Intelligent Robots and Systems*.
- Shen, W.-M., 1994: *Autonomous Learning from the Environment* (Foreword by Professor Herbert A. Simon), W. H. Freeman, Computer Science Press.
- Ranasinghe and Shen, 2008: *The Surprise-Based Learning Algorithm*. Technical Report ISI-TR-651, USC Information Sciences Institute.
- Sproewitz, A., M. Asadpour, Y. Bourquin, and A.J. Ijspeert, 2008: An active connection mechanism for modular self-reconfigurable robotic systems based on physical latching. *IEEE International Conference on Robotics and Automation*.
- Suh, J.W., S. B. Homans, and M. Yim, 2002: "Telecubes: Mechanical design of a module for self-reconfigurable robotics," in *IEEE Intl. Conf. on Robotics and Automation (ICRA)*, pp. 4095-4101.
- Murata, S., E. Yoshida, A. Kamimura, H. Kurokawa, K. Tomita, and S. Kokaji, 2002: "M-TRAN: Self-reconfigurable modular robotic system," *IEEE/ASME Transactions on Mechatronics*, vol. 7, no. 4, pp. 431-441.
- Goldstein, S., J. Campbell, and T. Mowry, 2005: "Programmable matter," *Computer*, vol. 38, pp. 99-101.
- Zykov, V., E. Mytilinaios, B. Adams, and H. Lipson, 2005: "Self-reproducing machines," *Nature*, vol. 435, no. 7038, pp. 163-164.
- Karagozler, M. E., J. D. Campbell, G. K. Fedder, S. C. Goldstein, M. P. Weller, and B. W. Yoon, "Electrostatic

latching for inter-module adhesion, power transfer, and communication in modular robots,” in Proceedings of the IEEE International Conference on Intelligent Robots and Systems (IROS 07), October 2007.

Shen, W.-M. and P. Will. Docking in Self-Reconfigurable Robots. In Proc. 2001 IEEE/RSJ Intl. Conf. on Intelligent Robots and Systems, pp. 1049–1054, 2001.

Castano, A., A. Behar, and P. Will, 2002: “The Conro modules for reconfigurable robots,” *IEEE/ASME Trans. Mechatronics*, vol. 7, no. 4, pp. 403–409.

Yim, M., Y. Zhang, K. Roufas, D. Duffa, and C. Eldershaw, 2003: “Connecting and disconnecting for chain self-reconfiguration with polybot,” *IEEE/ASME Transactions on mechatronics, special issue on Information Technology in Mechatronics*.

Murata, S., E. Yoshida, H. Kurokawa, K. Tomita, and S. Kokaji, 2001: “Self-repairing mechanical systems,” *Autonomous Robots*, vol. 10, no. 1, pp. 7–21.

Jørgensen, M., E. Østergaard, and H. Lund, 2004: “Modular atron: Modules for a self-reconfigurable robot,” in *IEEE/RSJ Int. Conf. on Robots and Systems*, Sendai, Japan, pp. 2068–2073.

Unsal, C., H. Kilic, c, ote, and P. K. Khosla, 2001: “A modular self-reconfigurable bipartite robotic system: Implementation and motion planning,” *Autonomous Robots*, vol. 10, no. 1, pp. 23–40.

M. Nilsson, 2002: “Connectors for self-reconfiguring robots,” *IEEE/ASME Transactions on mechatronics*, vol. 7, no. 4.

Mondada, F., M. Bonani, S. Magnenat, A. Guignard, and D. Floreano, 2004: “Physical connections and cooperation in swarm robotics,” in 8th Conference on Intelligent Autonomous Systems (IAS8), pp. 53–60.

Murata S. and H. Kurokawa, 2007: “Self-reconfigurable robot: Shape-changing cellular robots can exceed conventional robot flexibility,” *IEEE Robotics & Automation Magazine*, March 2007.

Zykov V. and H. Lipson, 2006: “Fluidic stochastic modular robotics: Revisiting the system design,” in Proceedings of *Robotics Science and Systems Workshop on Self-Reconfigurable Modular Robots*, Philadelphia PA.

Rubenstein, M., K. Payne, P. Will, and W.-M. Shen, 2004: Docking among Independent and Autonomous CONRO Self-Reconfigurable Robots. In Proc. of *IEEE Intl. Conf. on Robotics and Automation*, pp. 2877–2882, New Orleans, USA.